



COLOR SORTA

with defect recognition



-  blueberries
-  cranberries

*high speed capacity
accuracy & simplicity
defect recognition*

FRESHTRACKER™ compatible



Design

The BBC Technologies Electronic Color Sorta is designed specifically to color sort small objects and combines high speed, accuracy and versatility with intelligent traceability to maximize the potential of any packing facility. The color sensors used enables the machine to sort across the full visible color spectrum and beyond what the human eye can detect.

Speed & Accuracy

BBC Technologies color-sorting equipment has been used to sort a variety of items including blueberries, cranberries, cherries, olives, and mussels at high speeds (up to 265 lb/120 kg per minute) and an accuracy of up to 95%.

User Interface

The user interface has been designed with simplicity in mind. Color sorting parameters can be easily set using a slider on the touch screen monitor.

Defect Recognition

Our vision-based technology has the additional ability to detect a range of characteristics; including over-ripe, diseased, bird pecked and decayed fruit.

Cleaning

The machine is built in stainless steel with particular care taken in design and construction to ensure the machine can be cleaned easily. To assist with cleaning an air operated ram opens the machine up like a clam shell for easy access to all external surfaces of the machine.

Specifications

The size of objects sorted can range from 3/16" (5mm) to 1-3/16" (30mm). The following models are available:

30" (760mm) wide	45 lane	9900 lb/hr (4500kg/hr)
36 (900mm) wide	54 lane	11900 lb/hr (5400kg/hr)
48 (1220mm) wide	72 lane	15900 lb/hr (7200kg/hr)

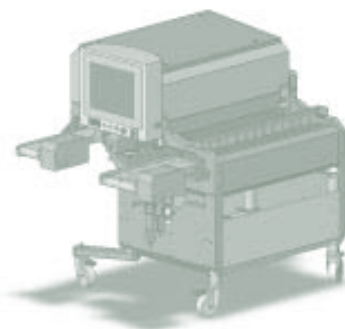

BBC Technologies provides a full range of production machinery including high-tech sorters and fillers, for fresh packing and processing operations. For more information, please contact a company representative:

EASTERN USA OFFICE

1201 Kalamazoo Street
South Haven, MI 49090, USA
ph/fax +1 269 639 8820
cell +1 269 491 9124

WESTERN USA OFFICE

Unit 4, 2812 Argyle Ave
Fresno, CA 93727, USA
ph +1 720 771 6325
fax +1 559 292 7488

NEW ZEALAND OFFICE

397 Jary Road,
RD1 Ohaupo, NZ
ph +64 (0) 7 823 6927
fax +64 (0) 7 823 6925

AUSTRALIAN OFFICE

ph +61 4 3496 9006
fax +64 7 3036 6480

EUROPE OFFICE

europe@bbctechnologies.com
Herenbosweg 30B
5962 NX Horst, Netherlands

SOUTH AMERICAN OFFICE

Galpón I Las Araucarias 9080
8720041 Quilicura, Chile
ph +56 (2) 571 4292

WARRANTIES & SUPPORT

- 24/7 Technical Support
- Annual pre-season service
- Live and local In-season service
- Remote service via internet connection



The user interface has been designed with simplicity in mind

