



SOFT SORTA

with patented 'Touch and Feel' technology



blueberries



grape & cherry tomatoes



cranberries

'touch and feel' technology
high speed capacity
accuracy & simplicity

FRESHTRACKER™ compatible

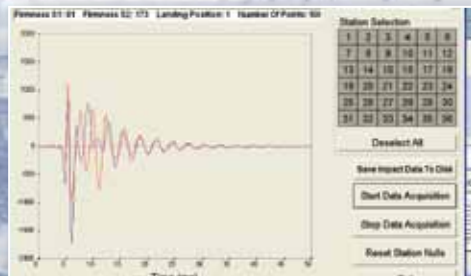

The Soft Sorter is designed to provide a high speed inline sort and removal of soft fruit. Using 'Touch and Feel' Technology, it remains the only product of its kind to provide an accurate test for fruit softness while maintaining gentle handling of product. In 2005 it was named one of the **Top Ten New Product Winners** at the World Ag Show in Tulare, California.

Design

The system is similar in design to Color Sorta in that the fruit travels over lanes, in this case 36. The fruit is then passed over "soft sensors" and if it is determined to be soft it is ejected by air solenoids.

Speed & Accuracy

This system will sort the fruit at a speed of up to 5000 pounds (2300 kgs) per hour. It will accurately reject over 80% of soft fruit.

User Interface

As with BBC Technologies' other products the Soft Sorta has been designed to be as simple to use as possible. Softness levels can be easily changed using a sliding scale on a touch screen monitor. Moving and electronics parts have been kept to a minimum and can all be easily replaced.

Optimised End-Product

With the ability to effectively identify and remove visibly undetectable soft and damaged fruit, the Soft Sorta is a key component of any fresh pack line, resulting in a high quality end product with an extended shelf life.

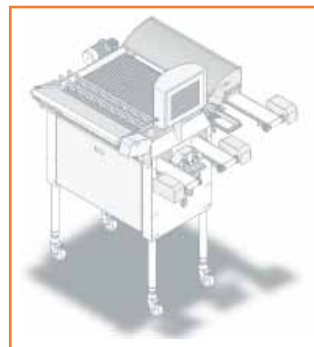

BBC Technologies provides a full range of production machinery including high-tech sorters and fillers, for fresh packing and processing operations. For more information, please contact a company representative:

EASTERN USA OFFICE
1201 Kalamazoo Street
South Haven, MI 49090, USA
ph/fax +1 269 639 8820
cell +1 269 491 9124

WESTERN USA OFFICE
Unit 4, 2812 Argyle Ave
Fresno, CA 93727, USA
ph +1 720 771 6325
fax +1 559 292 7488

NEW ZEALAND OFFICE
397 Jary Road,
RD1 Ohaupo, NZ
ph +64 (0) 7 823 6927
fax +64 (0) 7 823 6925

AUSTRALIAN OFFICE
ph +61 4 3496 9006
fax +64 7 3036 6480

EUROPE OFFICE
europe@bbctechnologies.com
Herenbosweg 30B
5962 NX Horst, Netherlands

SOUTH AMERICAN OFFICE
Galpón I Las Araucarias 9080
8720041 Quilicura, Chile
ph +56 (2) 571 4292

WARRANTIES & SUPPORT

- 24/7 Technical Support
- Annual pre-season service
- Live and local In-season service
- Remote service via internet connection
- FREE Software Upgrades

